

Tel – 07747 018544

www.prmrp.com

BRF-022 YGH SEALION

Building Instructions



**SCALE MODEL PRODUCT FOR ADULT MODELLERS ONLY.
WHITE METAL CONTAINS LEAD WASH HANDS AFTER USE.
MAY CONTAIN SMALL PARTS. ETCHED BRASS HAS FUNCTIONAL SHARP EDGES - HANDLE WITH EXTREME CARE**

Thank you for purchasing this kit.

This instruction pack should provide a guide for building this model, given some experience of soldering and the basics of etched kit construction.

Please read all the pack before starting to build.

Drawings and photos are essential for builders to acquaint themselves with the prototype they wish to model. I find that there are various website that provide excellent pictures of the real thing to help you complete the kit.

www.wagons.wordpress.com

www.ukrailrollingstock.fotopic.net

For builders of modern image in 7mm, consider joining MIGO+1, the Modern Image Gauge 0 & 1 Organisation. For more details check out the website www.migo.org.uk

Transfers are available from Fox Transfers

Suggestion of tools that maybe required and general kit assembly

Preparation

Before any parts are cut from the etched frets, push through any rivet holes from the back of the fret. These are represented by half etched holes on the rear of the fret. The same also applies to pre-formed loco.

Forming the Etched Parts

When forming the etches, unless otherwise instructed, the fold lines are on the inside. A pair of bending bars are ideal for this job or a vice, (without serrated jaws), would suffice.

Soldering

The key word for a successfully soldered joint is cleanliness. If the parts to be joined together are clean metal surfaces and are well coated in a good flux and providing the soldering iron tip has sufficient heat, a perfect joint which is also very strong will result.

A good strong joint can be achieved with glues but it is not easy to rework. A soldered joint can be easily undone, altered, corrected etc. by just re-applying some flux and heat from the soldering iron. The flux transfers the heat from the tip to the metal surfaces to be joined and stops oxidization at the joint. I allow the multi-core solder to stay molten on the joint and, when the iron is taken away, will cool to form a solid metal joint.

When undertaking any kind of soldering always hold the parts to be joined together securely and comfortably. You will learn with experience how long to hold the iron on and in turn how much pain your fingers can endure. The use of small clamps such as hair clips, mini G clamps, (not rubber bands!), a small vice, various pliers etc. will make life easier. A simple jig soldered together out of scrap metal or made from wood may also help for holding parts you find awkward to hold.

You can use the various temperature range solders to your advantage during building. Multi-core for larger pieces will give you the main structure. A solder called Carrs 145 or 177 solder is used to apply the finer etches and laminates. Finally white metal solder, Carrs 70 Red Label, is used to fix the castings on.

Remember to take care not to apply too much heat near laminates or casting you have already joined as you may disturb them.

Cleaning Up

When assembly is finished, all excess solder should be cleaned from the model. Files, small wire brushes, fibre pens and Wet & Dry paper are all useful aids when performing this task.

On your model there are joints between etches and castings that may require some filling. Car body fillers such as Isoxon are ideal, (avoid flexible/elastic fillers). When any solder or filler has been cleaned up the body should be washed in warm soapy water to remove any grease or flux that would prevent paint from adhering. Some washing up liquids leave a film on models, so it is recommended that Cillit Bang is used as a second wash. This removes all films, grease etc.

Plastic window boxes sold in the big DIY stores make an ideal size container for washing your models.

Rinse the model in clean water and leave to dry naturally over night.

Keeping the body square

Always build on a level surface. The last you thing you want is for your model to derail or wobble. Use a piece of 7mm Glass the squarest material you can get. This will ensure that you stand every chance of building a square model.

Tools

- A soldering iron with range of bits from large to very fine, for example a Weller temperature controlled iron (60 watt)
- Multi core solder, Carrs "Green Label" flux aids the running of the solder#18-24"
- Steel rule
- Folding bars such as those sold by M&M Models
- Range of Swiss files
- Medium cut bench knife such as Stanley Knife or short bladed scissors for cutting out etches.
- Evo Stick/Super Glue and Epoxy
- Good quality side cutters
- Fine pliers and duck billed pliers
- Mini drill and a good range of drills

Right lets get started!!!!!!!!!!

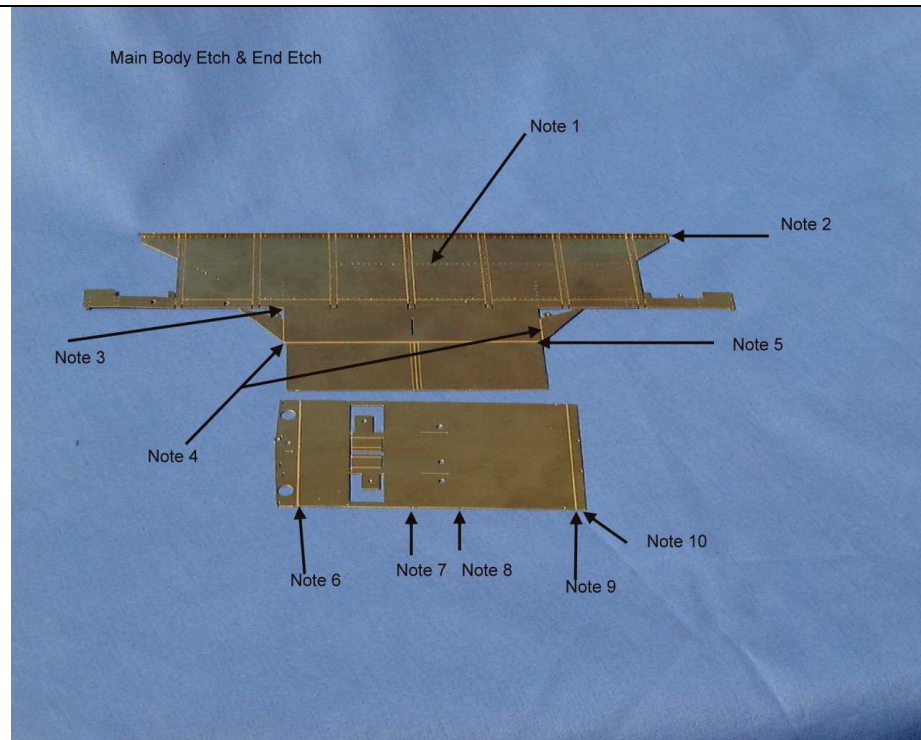

MAIN BOBY CONSTRUCTION – Repeat Twice

This picture shows one of the two body sides face up and one end face down..

Note 1.

Push through all the rivet detail before commencing any bending.

Note 2.

Fold the lip on the top of the body side at an angle of 90 degrees

Note 3.

Fold the top of the ballast shoot at a 90 degree angle into the body (IE the fold line is on the underside)

Note 4.

Fold out the two shoot sides at a 90 degree angle

Note 5.

Fold the base of the shot to an angle that allows it to side on the underside of the two sides folded in Note 4.

Solder All joint lines accordingly and repeat on the second body side.

Note 6.

Fold the buffer beam at a 90 degree angle

Note 7.

Fold the line indicated here on the underside to approximately 45 degrees. Don't worry about being to exact. You will get the right angle when you solder the end to the main body.

Note 8.

Fold this line indicated here on the underside to a 90 degree angle

Note 9.

Fold this line to a 45 degree angle

Note 10.

Fold this line to a 90 degree angle to form the lip to match the body side lip.

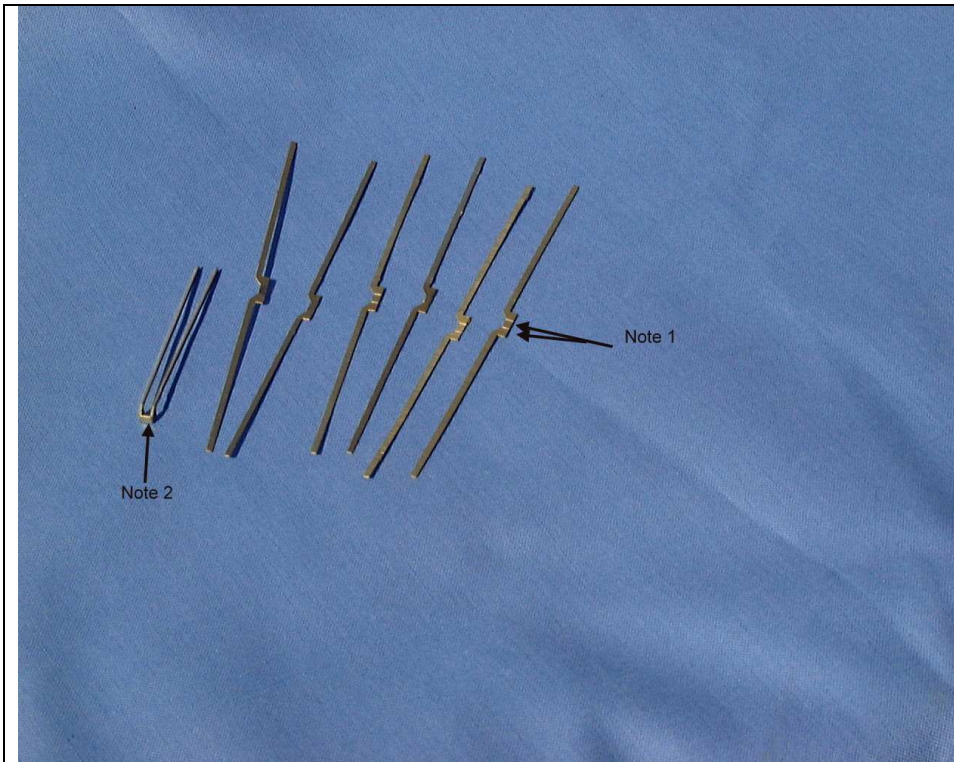

Side Struts

Note 1.

Fold up the 14 side struts so they look the finished article in note 2. Proceed to solder these to the body sides feeding the small tag at the arrow tip in note 2 into the body side slots for the middle three. Secure the remaining for each side by resting the tag on the under side of the body. The long part of each strut will sit in the half etched line on the body side and offer up to the top lip.

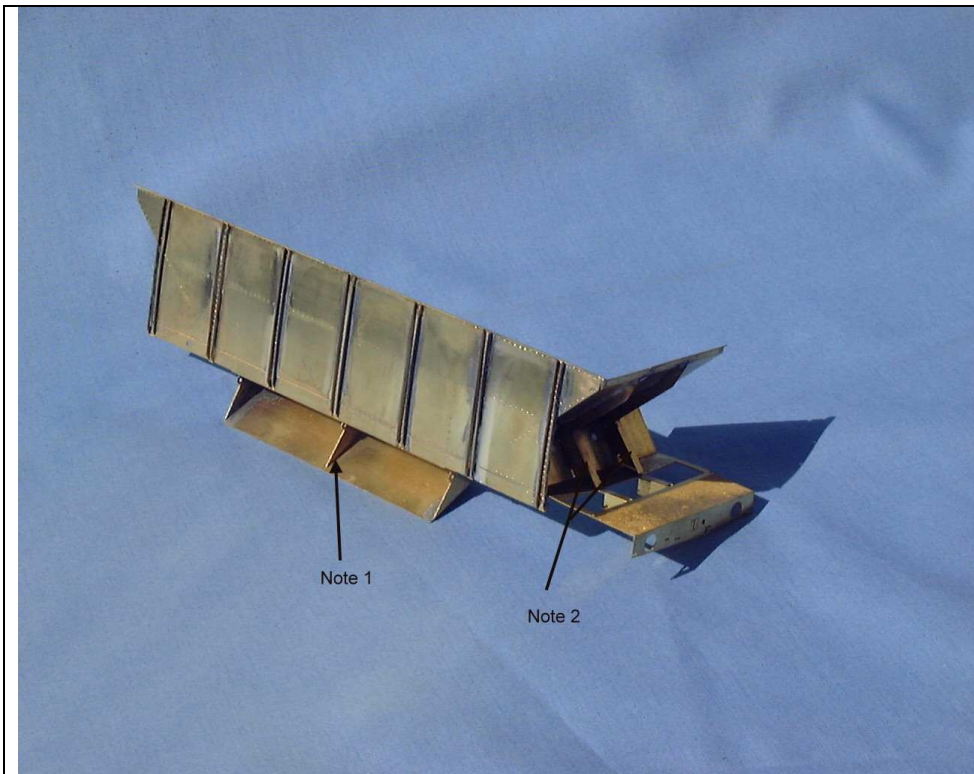

Note 1.

Fit the shoot centre piece using the slot provided

Note 2.

Fold and fit the L-shape brackets in the slots provided. This can be done before you begin to assemble the body and solder the end piece in place. This will give you the correct angle for your ends as detailed earlier.

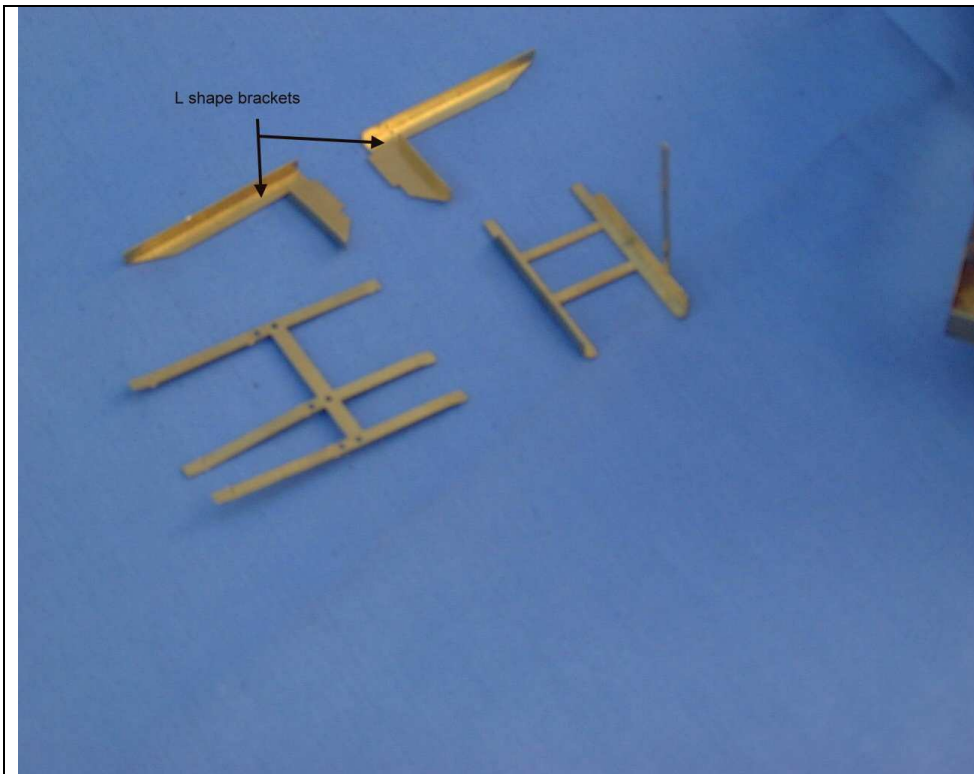

L Shape Brackets referred to above

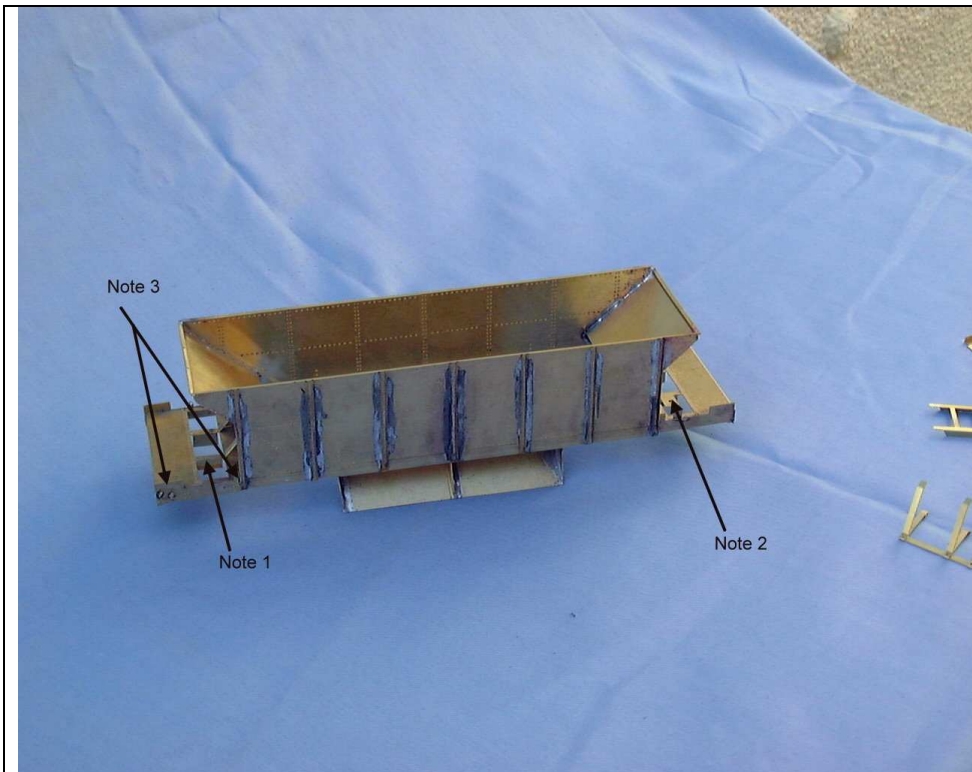

Note 1

Fold the remaining tabs on the ends. These simulate a girder running under the body.

Note 2.

On the second end there are one additional tab that folds up to take the Air Distribution Cylinder.

Final (although this picture does not show it) Fold down the four tabs each end indicated. The two end sections will sit on these.

Once you are happy solder the body together as indicated. This is what the end result should look like. Be careful to make sure the body is square throughout this process!!!! You will make reap the rewards at the end – Trust me!

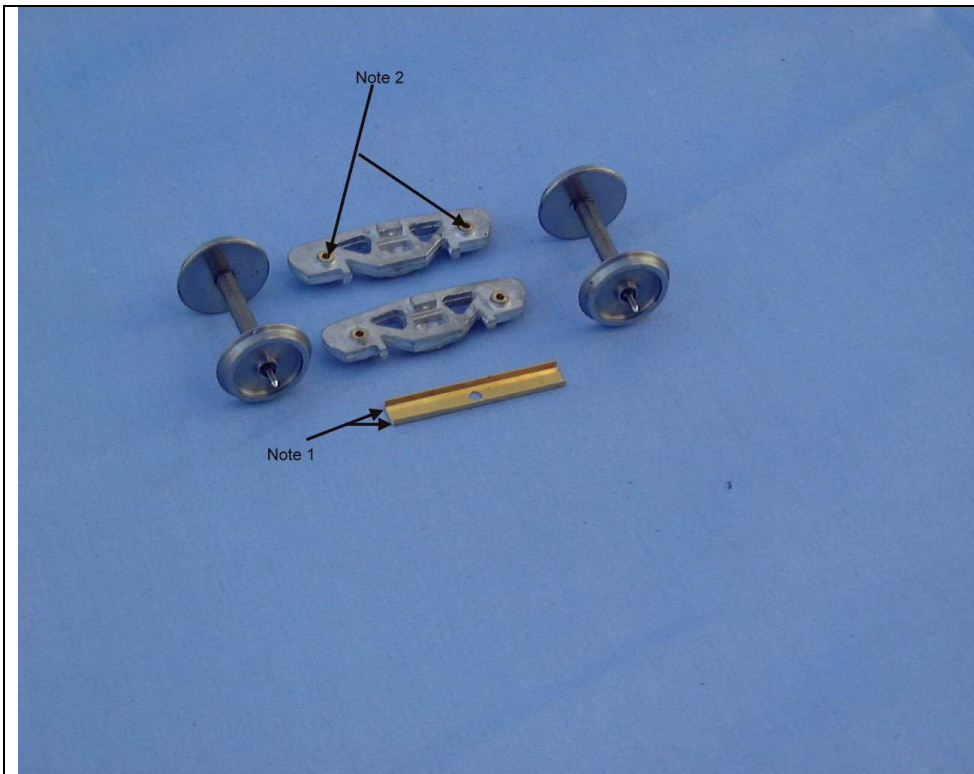

Note 1.

Fold the bogie stretcher

Note 2.

Drill and secure the top hat bearings in the bogie sides. I normally secure with a drop of super glue.

Repeat for the second bogie.



This is the finished article.

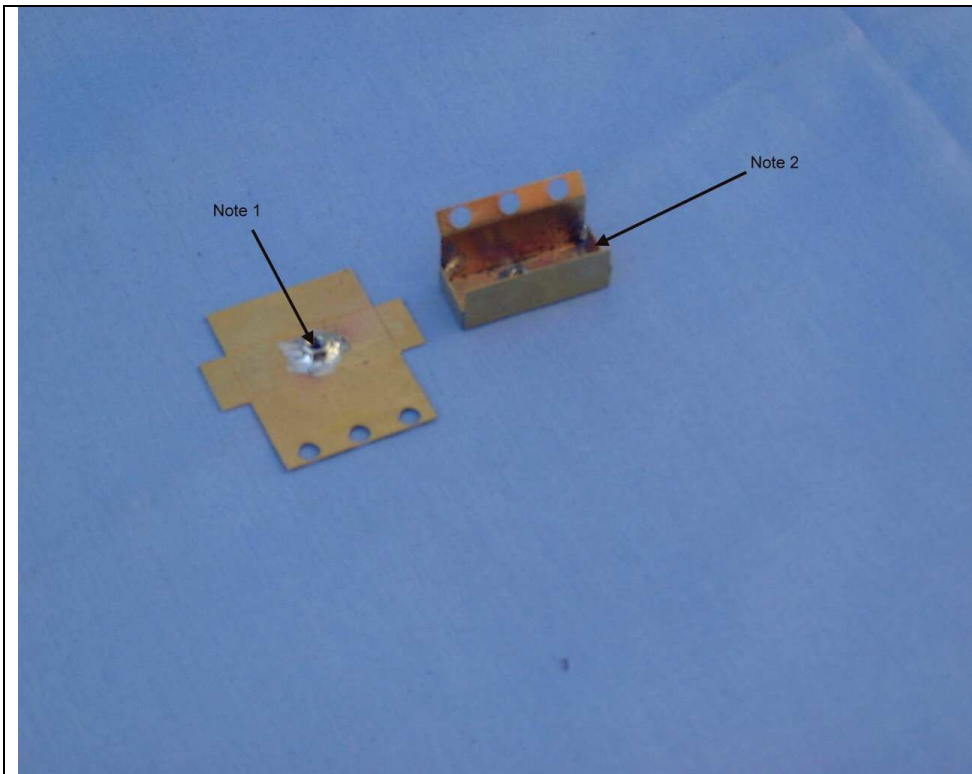

Note 1.

Fix the nut provided to the inside of the bogie mount box as indicated.

Note 2.

Fold up the box.

When complete, solder them in place on the underside of the body. The shorter of the two sides will sit flat on the underside of the end section offering up to the two 'girder sections' which were referred to earlier. The longer on the two sides will then join to the angle section of the end. Note that the section of this side with the three holes can now bend bent accurately to mirror the angle of the surface that it is being solder on.

Make sure that the centre of the nut is central to the body.

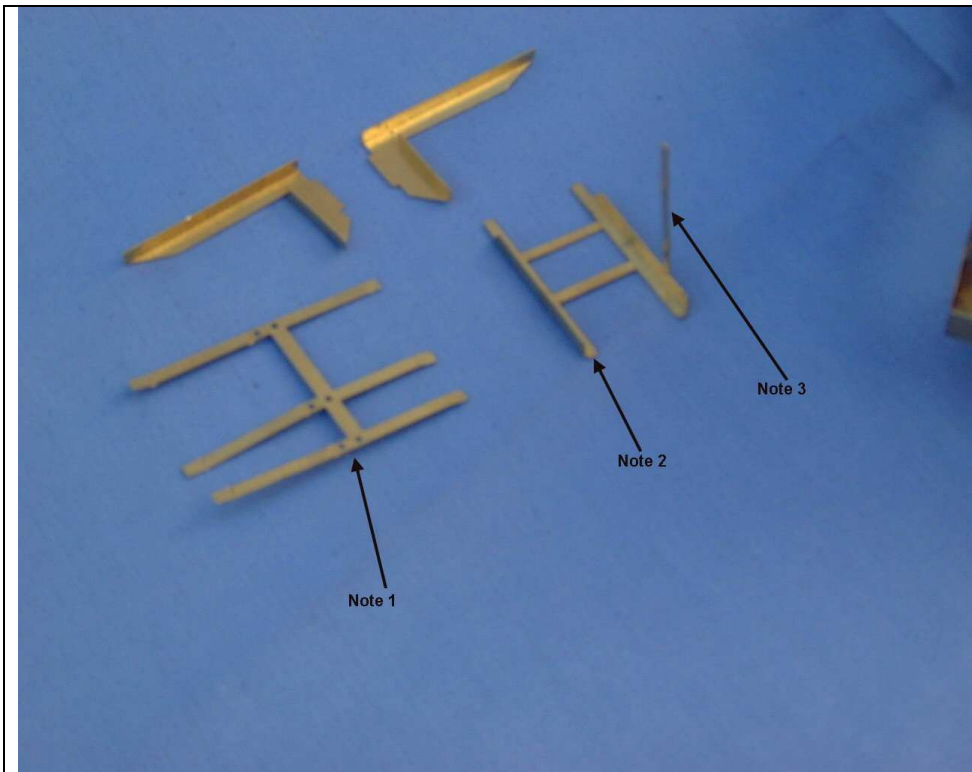

The end of the wagons start to get a bit busy now, so I have tried to make the instructions as simple as possible.

Note 1.

Fold the bracket as indicated in the line drawing given below. This will for the bracket that supports the door opening wheels and rods.

Note 2,

Fold the bracket as indicated in the line drawing below, making reference to the fact that the part marked with Note 3. Bends back on itself and around the front. Before fitting solder tack the large air tank to the inside of the cross girder that is to be fitted to the end with the Air Brake Cylinder and the small air tank to the end with the Vacuum Cylinders.

Proceed to fit the two brackets in place using the next two pages of pictures to help you.

Finally Laminate and fit the buffer beam etch on each end of the wagon

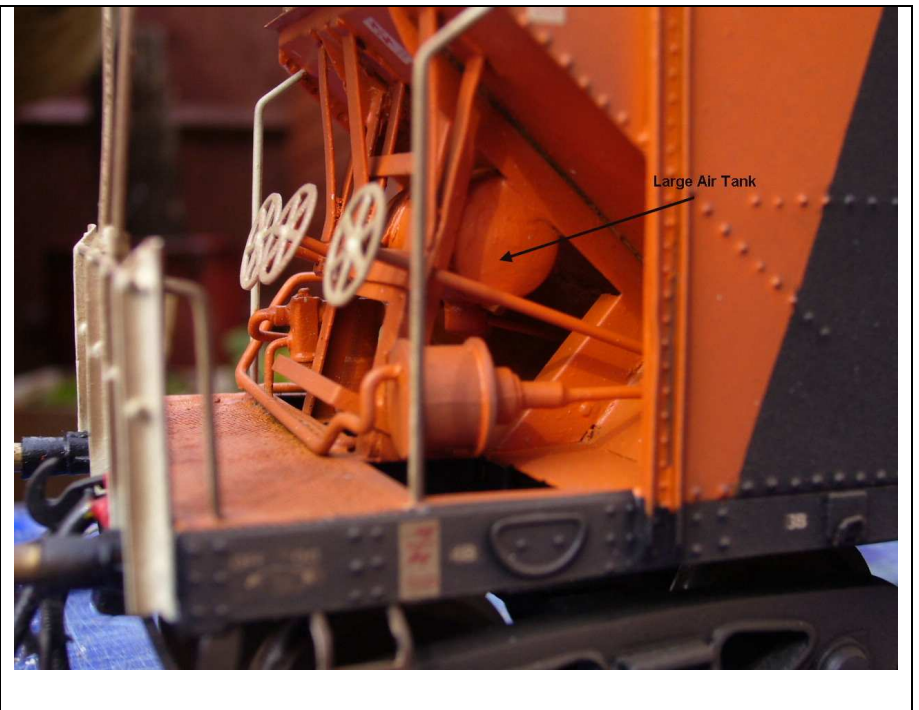
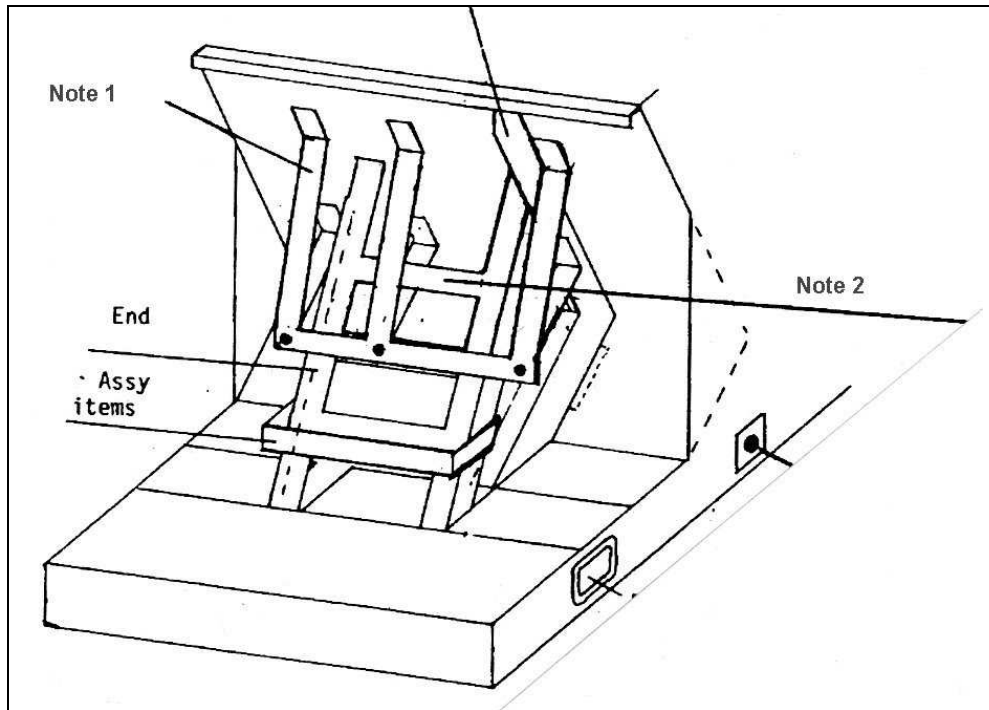

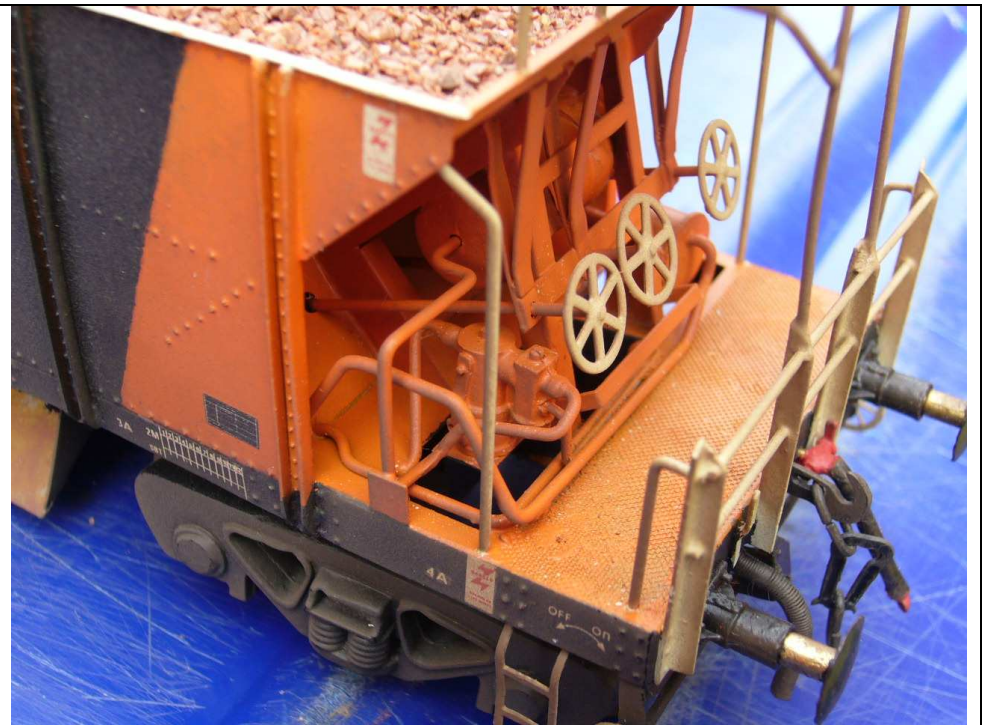
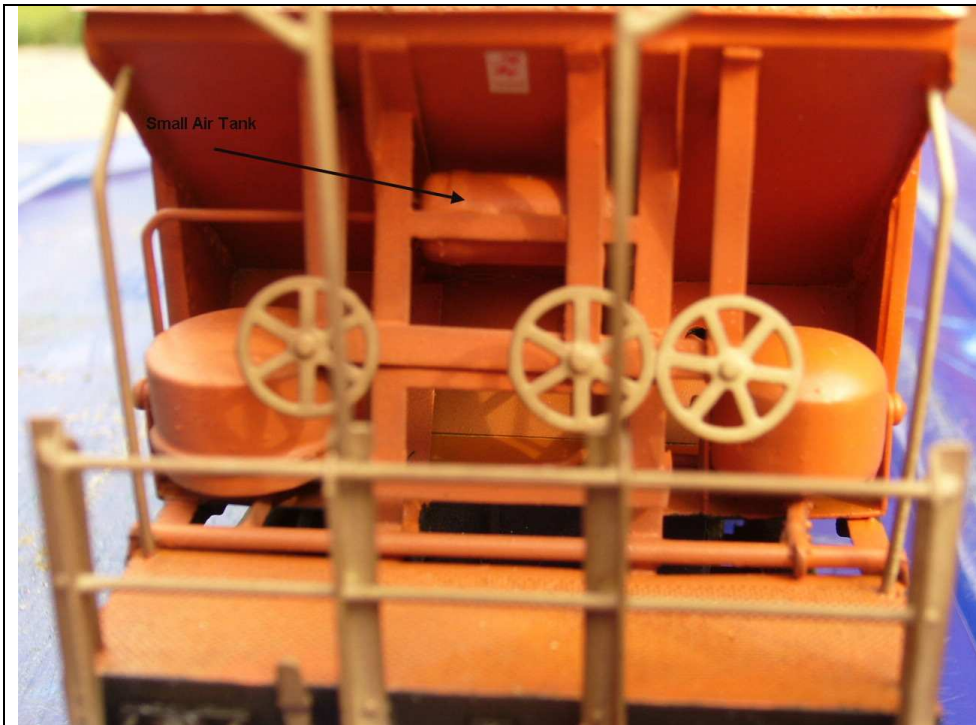

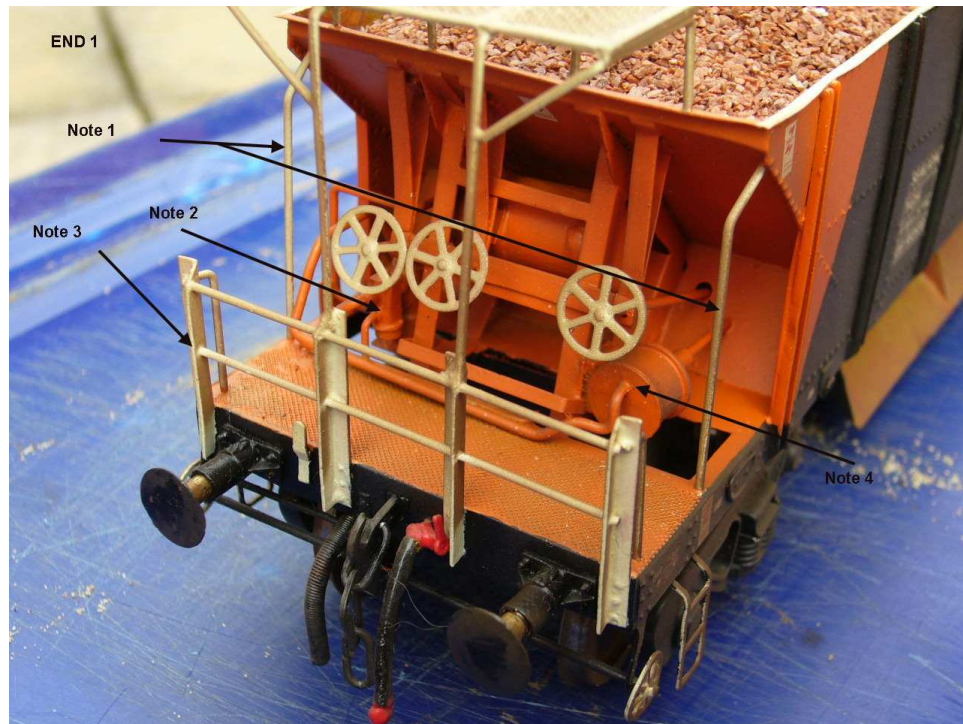

Note 1.

Fit the end hand rails

Note 2.

Fit the Distribution Valve

Note 3.

Fit the end handrail stantions and finish off with brass wire

You may wish to use wire to replicate the pipework to and from the cylinders. The layout of this can be used by looking at the last series of pictures and remains the modelers choice.



Note 1.

Fit the large Air Cylinder using the bracket provided. Not the difference in the two cylinders.

Note 2.

Fit the smaller of the two cylinders

Connect these two cylinders using the etched piston link for the larger cylinder and the cast unit for the smaller cylinder. You will then find two V-shaped etched pieces that solder to the bodyside to support a length of brass wire that runs the width of the wagon passing through the two holes of the piston links.

You may wish to use wire to replicate the pipework to and from the cylinders. The layout of this can be used by looking at the last series of pictures and remains the modeler's choice.

Fit all handrails as per End 1.



Finishing Off with Variant one of the safety canopy

Note 1

Fabricate and fit the safety canopy with the brass square provided. Fill in the hole in this with a square of brass mesh provided. Use brass wire for the supports.

Note 2

Fold and fit the brake rod bracket to the back of the buffer beam at end no.1

Note 3

Fit the brackets and wheels on each side, linking with a piece of brass wire.

Note 4.

Fit the steps and bend so that the bogies are able to turn.

Note 5

Fit the makers plate

Note 6

Fit the load consist clip.



This is the second variant of the safety canopy that is not covered by this kit, but easy to fabric with some off cuts of brass, a little more wire and mesh.

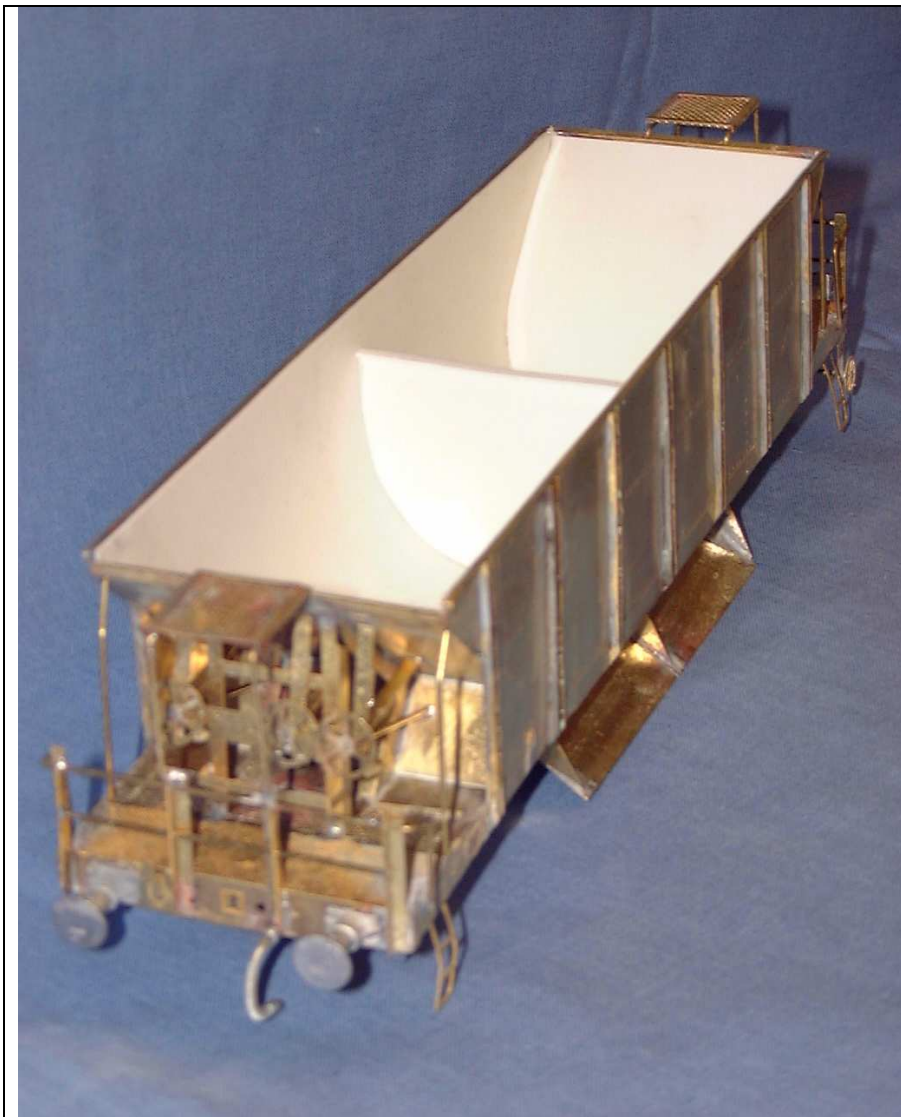

You may wish to add an interior to your kit. This can be done in plastic card using the templates below.

